

U1LiFePRO™

Quick Start Guide

inVENTUS™
POWER

S-12V40-U1
S-24V20-U1



Designed & Manufactured by

inVENTUS™
POWER

Inventus Power, Inc.
1200 Internationale Parkway
Woodridge, IL 60517

inventuspower.com
info@inventuspower.com
+1 877.423.4242

Applicable Models

Model	Part No. (SMBus/CANopen)	Part No. (RS485/CANopen)
S-12V40-U1	57575-301	N/A
S-24V20-U1	N/A	57623-301

Document Information

Release Date	Revision	Scope of Change
2023-02-23	V2.5	Minor edits to version 2 release

Inventus Power® and U1LiFePRO™ are trademarks of Inventus Power.

Copyright© 2023 Inventus Power All rights reserved.

Technical Support

If you have any technical questions regarding the U1LiFePRO™ battery, please contact our technical support team at:

Phone: +1.877.423.4242

E-mail: tech_support@inventuspower.com

Please read the detailed User Manual first and refer to this guide as another quick resource.



Before installation or maintenance of your batteries, the following equipment is required:

- Rubber gloves
- Safety goggles or other eye protection
- Insulated Torque Wrench / Philips Screwdriver
- Voltmeter

Mechanical Features

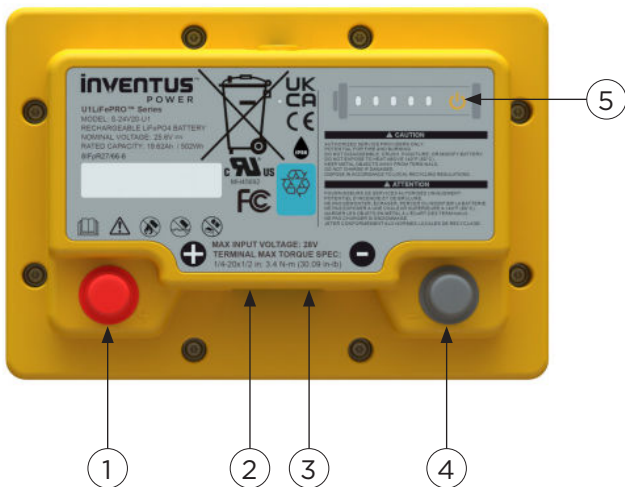

#	Description
1	Positive Terminal
2	Signal Connector #1
3	Signal Connector #2
4	Negative Terminal
5	Battery State of Charge Indicator

If in doubt, please consult with **Inventus Power Technical Support** (tech_support@inventuspower.com) on further instructions on the signal cable connections to the host system.

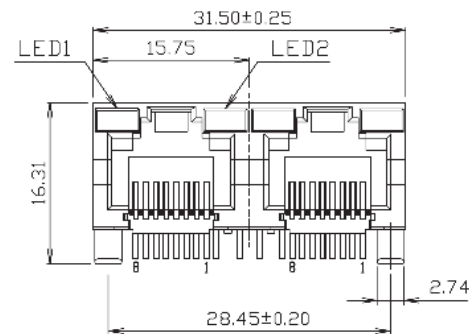

RIA Connector P/N: AJT3518821-030

Battery Terminal Torque Rating

Model	Terminal Type	Wrench Size	Torque (Nm)
S-12V40-U1 S-24V20-U1	ISO M6 x 1.0 x 16mm Bolt	10mm	3.4 ± 0.5 Nm

Wake-Up & Ship Mode

TO **WAKE UP** THE BATTERY
FROM SHIP MODE

Press the SOC button
for 5 seconds

We recommend to place the battery in Ship Mode when it is not used to prevent self-consumption current drain and extend storage life.



TO PLACE IN **SHIP MODE**

Press the SOC button
for 20 seconds

S-12V40-U1 can also receive a wake up signal from the signal connector by shorting pin 6 (VGND) to pin 4 (VINTLK) to wake up battery from Ship Mode.

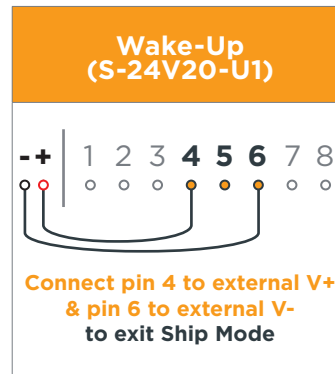
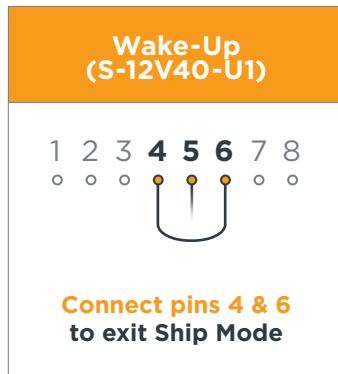

S-24V20-U1 can also receive a wake up signal from the signal connector by connecting pin 6 (VGND) and pin 4 (VINTLK) to a shared external voltage source to wake from Ship Mode.

Wake from Shutdown Mode

To exit Shutdown Mode, apply battery charge voltage pulse to the positive and negative terminals for >15 seconds.

Note: Many intelligent chargers sense voltage at the battery terminals prior to applying charge voltage and thus will not wake the battery from Shutdown Mode. In this case, it is recommended to use a power supply set to the appropriate charge voltage to wake the battery from Shutdown Mode.

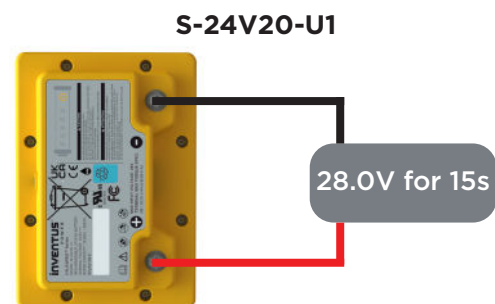
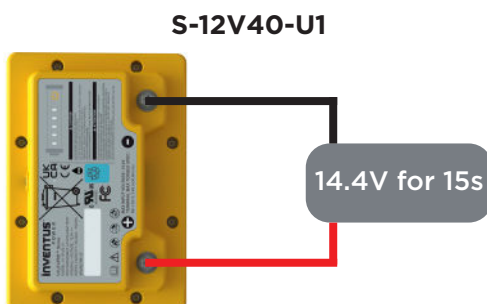

Power and Communication Cables

Power cables are not included with the battery unless a integration kit is purchased. Choose the appropriate power cable size based on the system load requirements. When connected in parallel configuration, it is preferable for all cables to be the same length size. Refer to ampacity table in User Manual when selecting power cables.

If your application requires communication, please use any off-the-shelf cable that is compatible with RIA Connector P/N: AJT3518821-030.

Charging

Many types of lead acid chargers are compatible with our U1LiFePRO™ batteries and safely charge between 0°C to 55°C (32°F to 131°F). The charger maximum voltage output should match the maximum charge voltage shown in the table below. It is recommended to charge the battery prior to installation. Consult with Inventus Power for recommendation on selecting a battery charger.

Charge Voltage / Current

Model	S-12V40-U1	S-24V20-U1
Charge Voltage	14.4 VDC	28 VDC
Series Charge Voltage (Two Batteries)	N/A	56 VDC
Recommended Charge Current	20A (0.5C)	10A (0.5C)
Maximum Charge Current	40A (1.0C)	20A (1.0C)

Pin Definition (S-12V40-U1)

Pin #	Symbol	Description
1	SMBDAT	SMBDAT; leave floating when using CAN
2	SMBCLK	SMBCLK; leave floating when using CAN
3		<i>not used</i>
4	VINTLK	For charging, connect VGND to VINTLK
5	VWAKE	For discharging, connect VGND to VWAKE
6	VGND	Ground reference to pull wake and interlock pins low
7	VCANH_BATT	CAN High (Battery)
8	VCANL_BATT	CAN Low (Battery)

Pin Definition (S-24V20-U1)

Pin #	Symbol	Description
1	A-RS485	RS485 Data A; leave floating when using CAN
2	B-RS485	RS485 Data B; leave floating when using CAN
3	PACK_S_ID	Pack series configuration ID, leave floating when pack series configuration is not implemented.
4	VINTLK	Interlock input pin - active high voltage (3.3V to 28V) to enable charging
5	VWAKE	Wake up pin - active high voltage (3.3V to 28V) to enable discharging
6	VGND	Ground reference for wake and interlock pins
7	VCANH_BATT	CAN High (Battery)
8	VCANL_BATT	CAN Low (Battery)

Connecting the Battery

1. Remove power to the vehicle/device prior to installation of the U1LiFePRO™ battery.
2. Remove all other batteries from the system prior to replacing them with U1LiFePRO™ batteries.
3. Ensure the U1LiFePRO™ battery is in Ship Mode to remove power for safe install.
4. Remove the protective battery terminal covers from the terminals. Retain these covers in the event that you need to remove or move the battery at some future time.
5. Attach the negative cable from the device to the negative terminal on the battery.
6. Attach the positive cable from the device to the positive terminal on the battery.
7. Attach the signal communications cable to the RJ45 ports if needed.
8. If the battery charger is integrated with the device drawing power from the U1LiFePRO™ battery, then please follow manufacturers recommended sequence for each battery connection.
9. It is recommended to fully charge and fully discharge the battery system upon initial connection to properly calibrate the SOC.

Please contact Inventus Technical Support if the system requires more than 6 batteries.

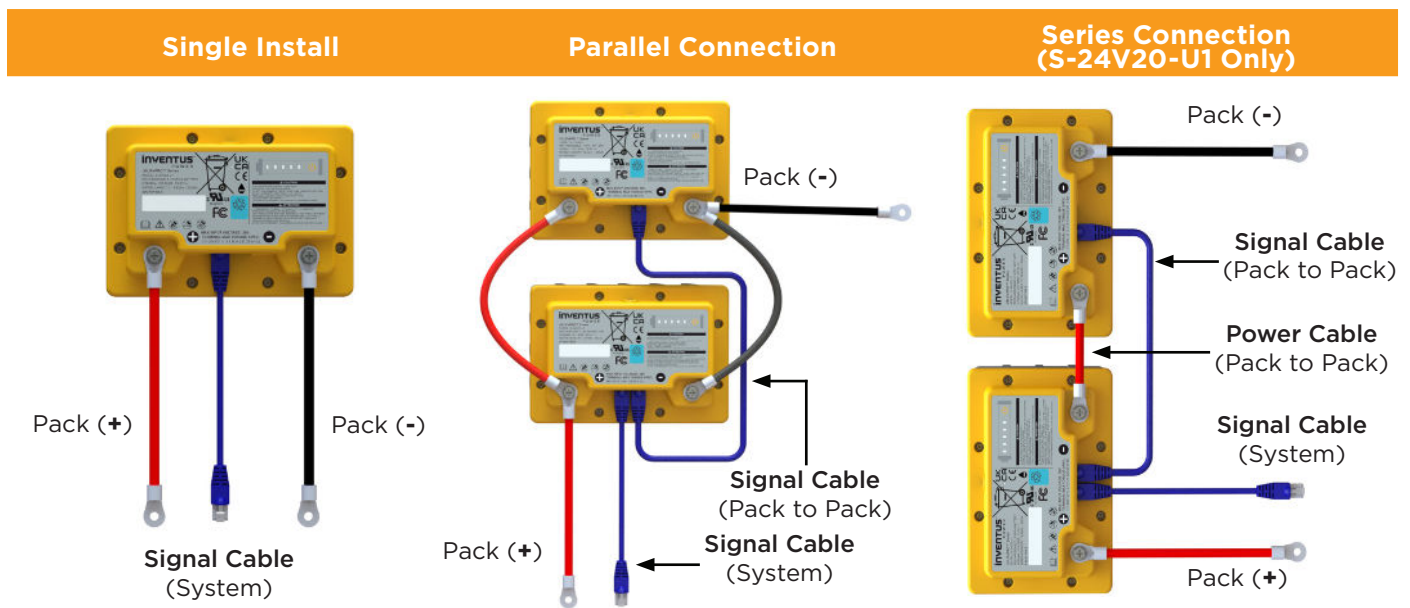

Module connections

The PROformance batteries can be connected in parallel to increase your energy requirements. You may connect up to 6 batteries for the S-12V40-U1 and S-24V20-U1 models. S-24V20-U1 can be connected in series up to 2 batteries. S-12V40-U1 batteries cannot be connected in series. Refer to wiring diagram below.





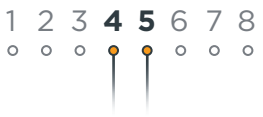



Note: CAN lines in the battery pack DO NOT have internal termination resistance. It is recommended to properly terminate the system and battery CAN Bus lines following the CAN Bus termination standards. For any technical questions about properly adding termination resistance, please contact technical support at tech_support@inventuspower.com.

Battery Modes (S-12V40-U1)

Sleep Mode (Terminals ON)	Charge Mode	Discharge Mode
 <p>Disable pins 4 & 5, wait 5 min to enter Sleep Mode</p>	 <p>Charge Current $\geq 500\text{mA}$ to enter Charge Mode</p>	 <p>Discharge Current $> 500\text{mA}$ to enter Discharge Mode</p>

Mode Name	VWAKE	VINTLK	Action	Mode Description
Sleep, Terminals ON	Off (Open)	Off (Open)	Disable pins 4 & 5 and wait 5 minutes to enter Sleep Mode	Sleep, Terminals ON MOSFETs open
Charge	N/A	N/A	Charge current $\geq 500\text{mA}$ to enter charge mode	Charge allowed, MOSFETs closed
Discharge	N/A	N/A	Discharge current $> 500\text{mA}$ to enter discharge mode	Discharge allowed, MOSFETs closed
Ship	N/A	N/A	Press the SOC button and hold for 20 sec to place in Ship Mode	Low power mode, MOSFETs open
Shutdown	N/A	N/A	Apply charge voltage to exit Shutdown	Lowest power mode, MOSFETs open

LED Status

LED Indicator Status	SOC
	80 - 100%
	60 - 79%
	40 - 59%
	20 - 39%
	10 - 19%
	<10%

Battery Modes (S-24V20-U1)

Sleep Mode (Terminals ON)	Charge Mode	Discharge Mode
<p>Disable pin 5 & wait 5 min to enter Sleep Mode</p>	<p>Charge Current $\geq 500\text{mA}$ to enter Charge Mode</p>	<p>Discharge Current $> 500\text{mA}$ to enter Discharge Mode</p>

Mode Name	VWAKE	VINTLK	Action	Mode Description
Sleep, Terminals ON	Off (Low)	N/A	Disable pin 5 and wait 5 minutes to enter Sleep Mode	Sleep, Terminals ON MOSFETs open
Charge	N/A	N/A	Charge current $\geq 500\text{mA}$ to enter charge mode	Charge allowed, MOSFETs closed
Discharge	N/A	N/A	Discharge current $> 500\text{mA}$ to enter discharge mode	Discharge allowed, MOSFETs closed
Ship	N/A	N/A	Press the SOC button and hold for 20 sec to place in Ship Mode	Low power mode, MOSFETs open
Shutdown	N/A	N/A	Apply charge voltage to exit Shutdown	Lowest power mode, MOSFETs open